

7SG26 Tau

Auto Re-close

Document Release History

This document is issue 2010/02. The list of revisions up to and including this issue is:
Pre release

2010/02	Document reformat due to rebrand
---------	----------------------------------

Software Revision History

The copyright and other intellectual property rights in this document, and in any model or article produced from it (and including any registered or unregistered design rights) are the property of Siemens Protection Devices Limited. No part of this document shall be reproduced or modified or stored in another form, in any data retrieval system, without the permission of Siemens Protection Devices Limited, nor shall any model or article be reproduced from this document unless Siemens Protection Devices Limited consent.

While the information and guidance given in this document is believed to be correct, no liability shall be accepted for any loss or damage caused by any error or omission, whether such error or omission is the result of negligence or any other cause. Any and all such liability is disclaimed.

Attached is a mechanical drawing for the Epsilon E8 case size with panel cut-out and drilling dimensions.

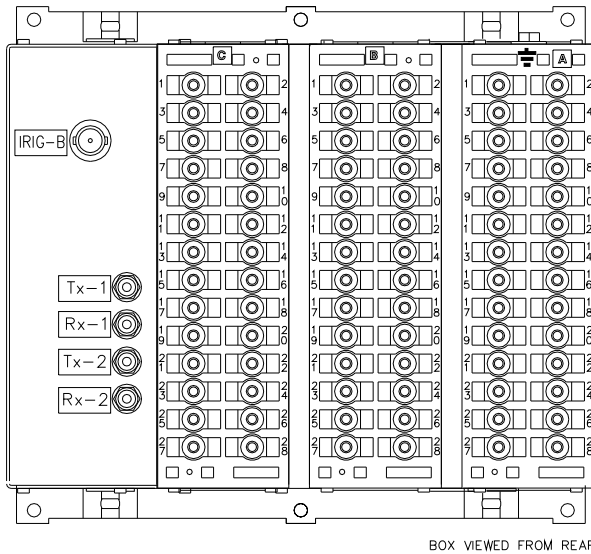

NOTES

1 TERMINALS RECOMMENDED ARE PRE INSULATED & MUST BE CRIMPED USING APPROVED TOOLING. AMP PIDG OR PLASTI GRIP FUNNEL ENTRY (RING TONGUE) FOR M4 FIXING STUD.

SUPPLIER	AMP	CABLE SIZE
AMP	342103	0.25-1.6 SQ MM
AMP	342143	1.0-2.6 SQ MM.

OR ANY OTHER MANUFACTURERS EQUIVALENT TERMINAL.

2 FOR OUTLINE & DRILLING DRG SEE 2995X10008 (A4). FOR 19" RACK MOUNTING USE FRAME 2994B10046.

